

Dow Corning® DefendAir 200: Application Guide

# Build a Better Barrier™



High Performance Building  
Solutions

# *Dow Corning*<sup>®</sup> DefendAir 200 Application Guide

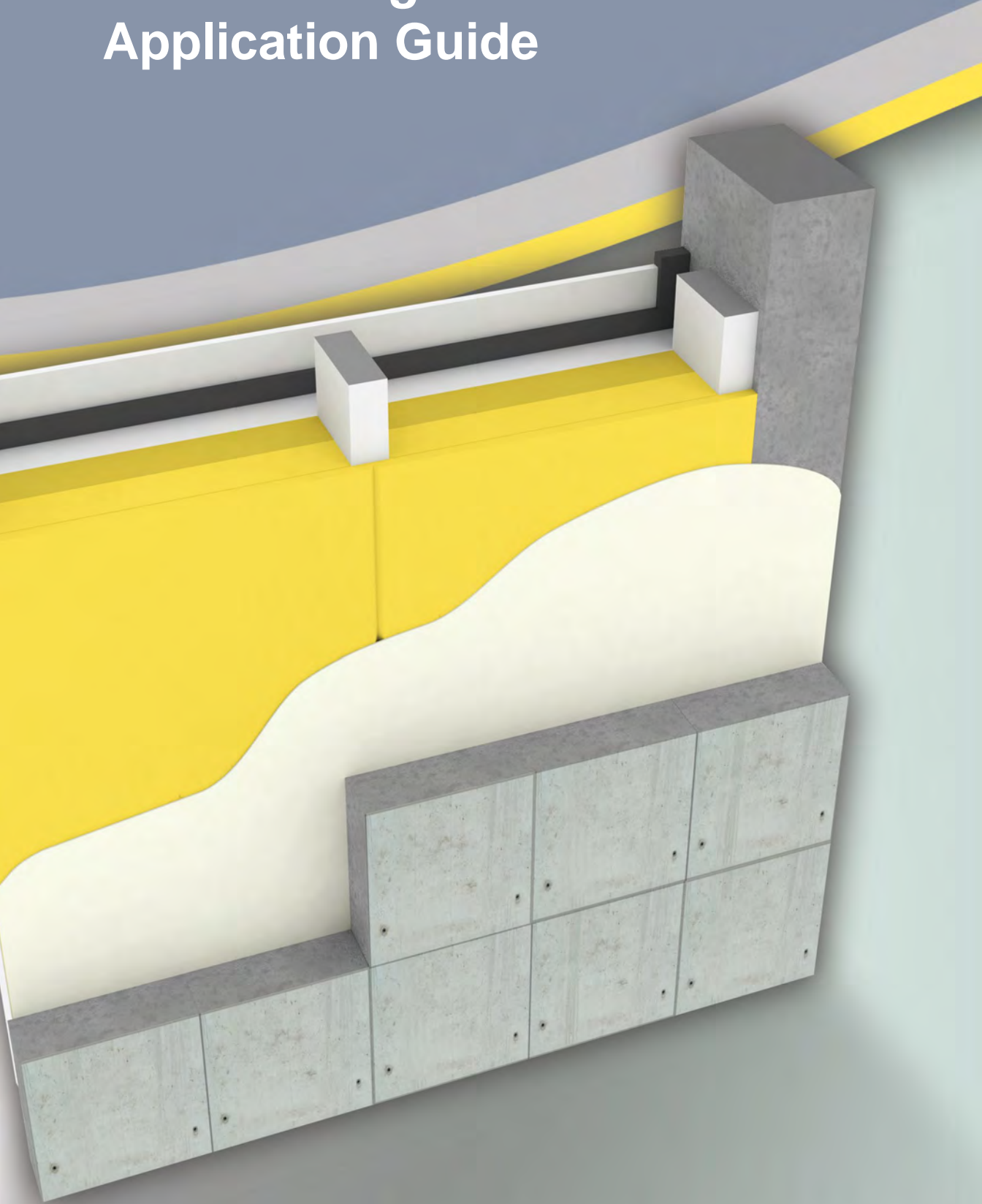



## **Contents**

This document is intended to provide installation and field testing guidance for *Dow Corning®* DefendAir 200.

## **Product Descriptions**

### ***Dow Corning®* DefendAir 200 Silicone Liquid Applied Air and Weather Barrier**

*Dow Corning®* DefendAir 200 is a 100 percent silicone liquid-applied air and weather barrier designed to protect against uncontrolled air infiltration and water penetration. The vapor-permeable, one-component, water-based coating dries to form a flexible membrane that is impervious to water, but has the ability to “breathe,” allowing water vapor to escape from inside the substrate. It is a one-part, water-based silicone elastomer that can be brush-, roller- or spray-applied.

The coating provides long-term protection from air infiltration and water penetration and the elements while allowing for normal movement imposed by seasonal thermal contraction and expansion. The coating maintains its air and water protection properties even when exposed to sunlight, rain, snow or temperature extremes.

### ***Dow Corning®* Silicone Transition System**

*Dow Corning®* Silicone Transition System (STS) is comprised of a preformed silicone strip and molded pieces designed for flashing and transition applications to weatherproof against air and water infiltration.

### ***Dow Corning®* 791 Silicone Weatherproofing Sealant**

*Dow Corning®* 791 Silicone Weatherproofing Sealant is a one-part, medium-modulus, neutral-curing silicone sealant for general weathersealing applications. Available in a wide variety of colors.

### ***Dow Corning®* 758 Silicone Weather Barrier Sealant**

*Dow Corning®* 758 Silicone Weather Barrier Sealant is a neutral, one-part silicone sealant designed for adhering to low-energy surfaces common in sheet or self-adhered air and weather-resistant barriers. Available in white.

### ***Dow Corning®* 778 Silicone Liquid Flashing**

*Dow Corning®* 778 Silicone Liquid Flashing is a one-part, liquid silicone flashing that can be trowel applied to weatherproof at window and door openings and other through cavity penetrations.

## UV Exposure

*Dow Corning*<sup>®</sup> DefendAir 200 does not have a limit on exposure time before being covered by the exterior cladding if applied in strict accordance with the requirements of this application guide. After the coating is installed, any delays in the construction schedule that will result in the coating being exposed longer than expected will not affect the performance of the material. Open-joint rainscreen applications where sections of the coating will remain exposed will not affect the performance of the material. When using in conjunction with *Dow Corning*<sup>®</sup> brand silicone sealants and transition materials, all components are approved for long-term UV exposure.

## Availability

*Dow Corning*<sup>®</sup> DefendAir 200 is available in 5-gallon (19 L), 44 lb (20 kg) pails and 55-gal (208 L), 507 lb (230 kg) drums. *Dow Corning*<sup>®</sup> DefendAir 200 is supplied in white or grey. It should not be tinted to another color prior to installation.

If a different color coating is desired, one 10-mil wet (5-mil dry) coat of *Dow Corning*<sup>®</sup> AllGuard Silicone Elastomeric Coating can be applied. *Dow Corning*<sup>®</sup> AllGuard Silicone Elastomeric Coating and *Dow Corning*<sup>®</sup> DefendAir 200 are compatible and will adhere to each other. *Dow Corning*<sup>®</sup> DefendAir 200 should be installed to the required 15-mil dry film thickness and all quality control performed before any *Dow Corning*<sup>®</sup> AllGuard Silicone Elastomeric Coating is applied.

## Coverage Rates

**Table 1. Estimated Application Rates<sup>(1)</sup> (15-mil [0.38 mm] Minimum Dry-Film Thickness)**

Texture/Substrate	Estimated Rate	
	ft <sup>2</sup> /gal	m <sup>2</sup> /L
Smooth (sheathing, precast concrete)	45-55	1.1-1.3
Medium (plywood)	30-45	0.8-1.1
Coarse (CMU)	20-30	0.5-0.8

<sup>(1)</sup>Application rates vary tremendously with porosity and degree of texture of the substrate. These values are estimated and should be confirmed at the job site prior to bidding the project.

Specific brands of the substrates (especially exterior grade sheathing) listed above may absorb more or less of the air barrier than is listed in Table 1. See the Tech Talk at the back of this guide for more information on specific substrates that have been tested. *Dow Corning*<sup>®</sup> DefendAir Primer may be required for some substrates. It is available in 5-gallon (19 L), 42 lb (19.1 kg) pails. See Table 4 for information on substrate preparation.

## Shelf Life

*Dow Corning*<sup>®</sup> DefendAir 200 has a shelf life of six months from the date of manufacture.

## Compatibility and Adhesion Between *Dow Corning*<sup>®</sup> Brand Products

*Dow Corning*<sup>®</sup> DefendAir 200 is compatible with many *Dow Corning*<sup>®</sup> brand sealant and precured silicone components. *Dow Corning*<sup>®</sup> DefendAir 200 is also compatible with *Dow Corning*<sup>®</sup> AllGuard Silicone Elastomeric Coating.

Table 2 contains a list of adhesion information for sealants commonly used with *Dow Corning*<sup>®</sup> DefendAir 200. Sealants in Column A can be applied over the air barrier 48 hours after the *Dow Corning*<sup>®</sup> DefendAir 200 is installed. Any sealant that adheres to *Dow Corning*<sup>®</sup> DefendAir 200 (Column A) can be used to install *Dow Corning*<sup>®</sup> Silicone Transition System over *Dow Corning*<sup>®</sup> DefendAir 200 in order to create a complete air and watertight system. (Note: *Dow Corning*<sup>®</sup> Silicone Transition System may also be installed under *Dow Corning*<sup>®</sup> DefendAir 200 using a sealant that adheres to the underlying substrate. Refer to the STS application guide for more information.)

*Dow Corning*<sup>®</sup> DefendAir 200 can be applied over any *Dow Corning*<sup>®</sup> brand sealants listed in Column B of Table 2 after they have been allowed to achieve tack-free cure, which ranges from approximately 15-45 minutes depending on the sealant and environmental conditions (see sealant data sheets for more specific tack-free times).

**Table 2. Adhesion Between *Dow Corning*<sup>®</sup> DefendAir 200 and *Dow Corning*<sup>®</sup> Brand Sealants**

	Column A	Column B
Sealant	Adheres to <i>Dow Corning</i> <sup>®</sup> DefendAir 200	<i>Dow Corning</i> <sup>®</sup> DefendAir 200 Adheres to Sealant
<i>Dow Corning</i> <sup>®</sup> 791 Silicone Weatherproofing Sealant	X	X
<i>Dow Corning</i> <sup>®</sup> 756 SMS Silicone Sealant	X	X
<i>Dow Corning</i> <sup>®</sup> 795 Silicone Building Sealant		X
<i>Dow Corning</i> <sup>®</sup> 758 Silicone Weather Barrier Sealant	X	X
<i>Dow Corning</i> <sup>®</sup> 790 Silicone Weatherseal Sealant		X

Please contact your local *Dow Corning* representative for information regarding the use of *Dow Corning*<sup>®</sup> brand products not listed here.

## Application and Service Temperature and Humidity

*Dow Corning*<sup>®</sup> DefendAir 200 can be applied at ambient air temperatures between 20°F (-6°C) and 100°F (38°C). Do not apply the coating when the relative humidity is greater than 90 percent, or when there is a threat of rain within 8 hours. Reference the Tech Talk for more information on damp substrate and rain applications.

There is no lower-limit temperature specifically for the substrate, but the surface must remain free of bulk water and frost. Do not apply *Dow Corning*<sup>®</sup> DefendAir 200 to surfaces above 120°F (49°C).

*Dow Corning*<sup>®</sup> DefendAir 200 has a service temperature range of -15°F to 300°F (-26°C to 149°C).

## Chemical Resistance

*Dow Corning*<sup>®</sup> DefendAir 200 has passed ASTM D543 (Alkalinity Resistance) in a solution of sodium carbonate with a pH of 12. The elongation and tensile properties of *Dow Corning*<sup>®</sup> DefendAir 200 were minimally affected after being submerged in the solution for 28 days. High pH exposure will not affect the expected performance characteristics of the material. A 15-mil sample of the air and weather barrier passes ASTM D1970 (Fastener Sealability) after being submerged in the pH 12 solution for 28 days.

*Dow Corning*<sup>®</sup> DefendAir 200 should not be applied to cast-in-place/precast concrete that has cured for less than 28 days. Thinner applications of cementitious based patching materials, such as, but not limited to, grouts and patch compounds, should be allowed to cure for 10 days prior to coating.

## Substrate Compatibility and Adhesion

*Dow Corning*<sup>®</sup> DefendAir 200 has been tested according to ASTM D4541 for adhesion on the substrates in Table 3. Where *Dow Corning*<sup>®</sup> DefendAir Primer is not required in the table below, it optionally may be used for more robust adhesion.

There are numerous other substrates that will come into contact with the air and weather barrier. Please contact your local *Dow Corning* representative for information on substrates not listed here.

**Table 3. Substrate Adhesion: Primer Requirements When Tested Per ASTM D4541**

Substrates That Do NOT Require Primer	Substrates That Require Primer
OSB	Plywood*
DensGlass <sup>®</sup> Gold <sup>(2)</sup>	Damp OSB
E2XP Sheathing	
SECUROCK <sup>®</sup>	
Permabase	
Concrete – Small Aggregate	
Concrete Masonry Unit	
Stainless Steel	
Galvanized	

## Workmanship Considerations

It is important to protect adjacent surfaces and surroundings that are not to be coated with the air and weather barrier.

## Application Instructions

### Step 1. Surface Preparation and Evaluation

All surfaces must be clean and free of excessive dirt, dust, oil, grease, mold, fungus, efflorescence, laitance, peeling coating and any other foreign material. Green concrete must be allowed to cure 28 days before application of *Dow Corning*<sup>®</sup> DefendAir 200 Silicone Liquid Applied Air and Weather Barrier. Large amounts of dust and dirt should be removed from the substrate through a light dusting of the surface using either a brush or dry cloth. If other substances are found on the substrate, refer to Table 4 for recommendations to ensure proper cleaning and preparation of the substrate prior to coating.

When installing *Dow Corning*<sup>®</sup> Silicone Transition System or another window transition system as part of the air and weather barrier system, follow the recommendations of the system manufacturer. For *Dow Corning*<sup>®</sup> Silicone Transition System, clean the substrate where the sealant is to be installed using a solvent and two-cloth cleaning method. Refer to the Americas Technical Manual (Form No. 62-1112) for more information on general sealant installation recommendations.

*Note: All system tests such as ASTM E2357 were performed using Dow Corning<sup>®</sup> brand sealants and Dow Corning<sup>®</sup> Silicone Transition System and are recommended to ensure the published system performance.*

**Table 4. Substrate Preparation**

Surface Conditions	Detection Method	Removal Method
Efflorescence	Wipe with dark cloth	Wire brush; then clean with high-pressure water. On stubborn deposits, mix 1 part muriatic acid (or similar) to 12 parts water, then clean with high-pressure water.
Laitance	Scrape with putty knife, looking for powdery material	Scrape with steel scraping tool followed by high-pressure water cleaning.
Mildew	Visual	Scrub with 5 percent bleach solution followed by high-pressure water cleaning.
Grease/oil	Visual; sprinkle water on surface	Trisodium phosphate (TSP) solution in hot water and high-pressure water cleaning.
Form release, curing or surface-hardening compounds	Visual; sprinkle water on surface	Must be removed by mechanical abrasion or abrasive water cleaning.

<sup>(2)</sup> ASTM E2357 was completed using DensGlass<sup>®</sup>

Gold as a substrate without *Dow Corning*<sup>®</sup> DefendAir Primer.

\*Results on plywood have been found to be variable. Project specific adhesion testing is strongly recommended.

## Step 2. Sealing Joints and Penetrations

### Substrate Joints, Defects and Holes

All joints between substrates or between sheets of exterior sheathing (such as those found in exterior grade gypsum or plywood sheets) should be sealed using a *Dow Corning®* brand sealant as listed in Column B of Table 2. The sealant should be tooled flush to the surface. No bond breaker is required for these joints provided they are static joints (Figure 1). Any unused nail holes as well as any countersunk or protruding nails and screws must be sealed (using the same sealant used to seal the joints) and struck flush to the surface of the substrate prior to the installation of *Dow Corning®* DefendAir 200. Screw and nail heads that are installed flush to the substrate and remain in the substrate do not need to be sealed separately prior to the installation of the air and weather barrier.

Defects in the substrate can be repaired flush to the surface using the same sealant as used for joints and penetrations (Figure 2) or a patching material recommended by the substrate manufacturer. Cementitious patches should be allowed to cure for a minimum of 10 days prior to installing the coating.

Changes in the substrate (Figure 3) and control joints (Figure 4) should be sealed as a traditional weatherseal joint. There are five basic steps for proper joint preparation and sealant application:

1. **Clean** – Joint surfaces must be clean, dry, dust-free and frost-free.
2. **Prime** – If required, primer is applied to the clean surface(s).
3. **Pack** – Backer rod or bond breaker is applied.
4. **Seal** – Sealant such as *Dow Corning®* 791 Silicone Weatherproofing Sealant is applied into the joint cavity.
5. **Tool** – Dry-tooling techniques are used to create a flush joint and to make certain the sealant has the proper configuration and fully contacts the joint walls.

Wall offsets or changes in plane can be sealed using a fillet bead of sealant (Figure 5). Bond breaker material does not need to be used unless greater than 15 percent movement is expected in the joint.

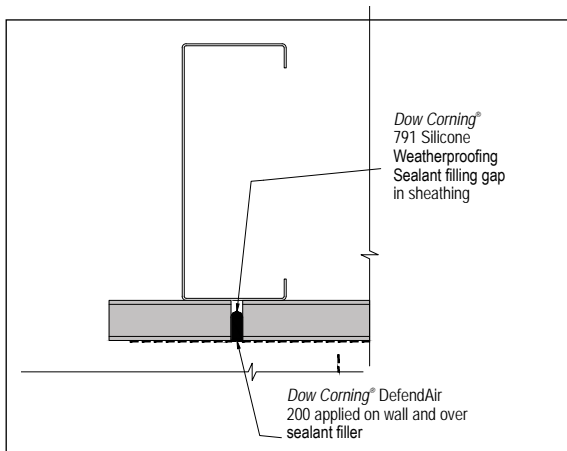

Figure 1. Gap in Sheathing

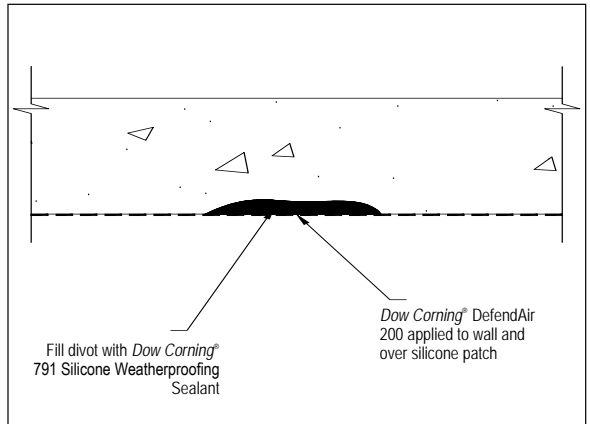

Figure 2. Divot in Concrete Wall

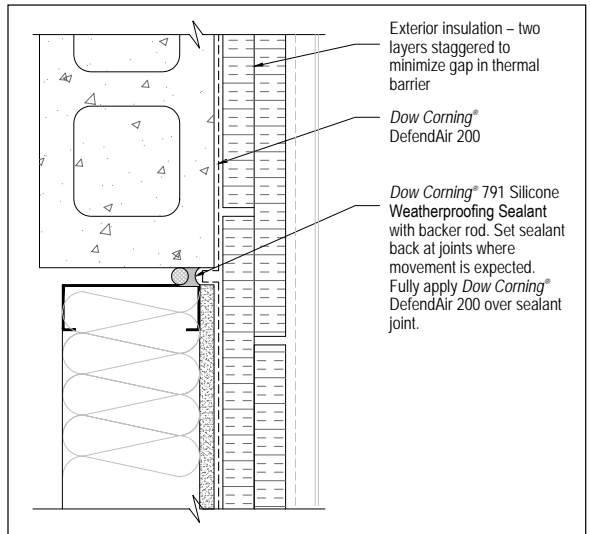

Figure 3. Change in Wall Substrate

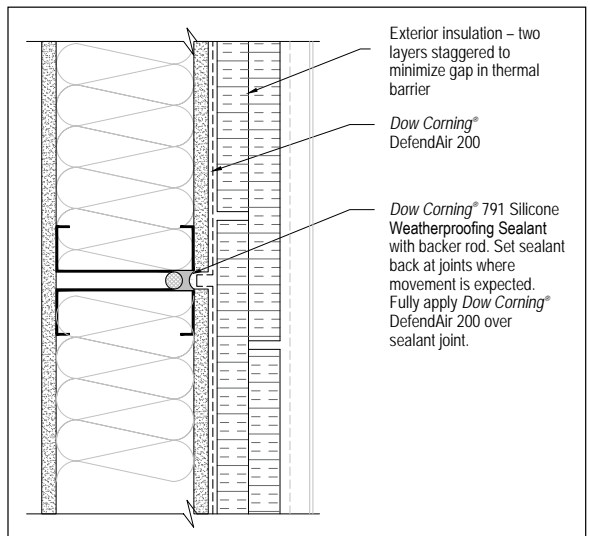

Figure 4. Control Joint



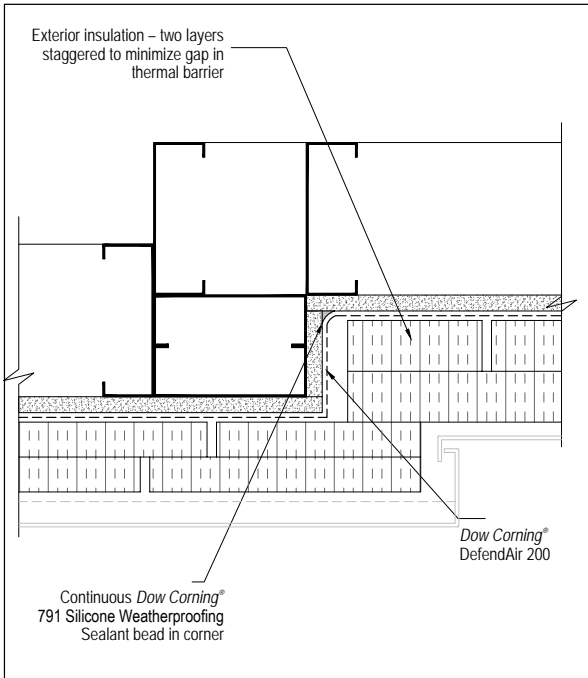

Figure 5. Vertical Wall Offset

**Penetrations**

Gaps around penetrations should be sealed in a similar manner using a sealant listed in Table 2. To reduce the amount of sealant used, a backer rod can be inserted into gaps greater than 1/4 inch (6.3 mm) and sealed as a traditional sealant joint (Figure 6).

For information on fasteners installed after the air barrier, refer to page 16.

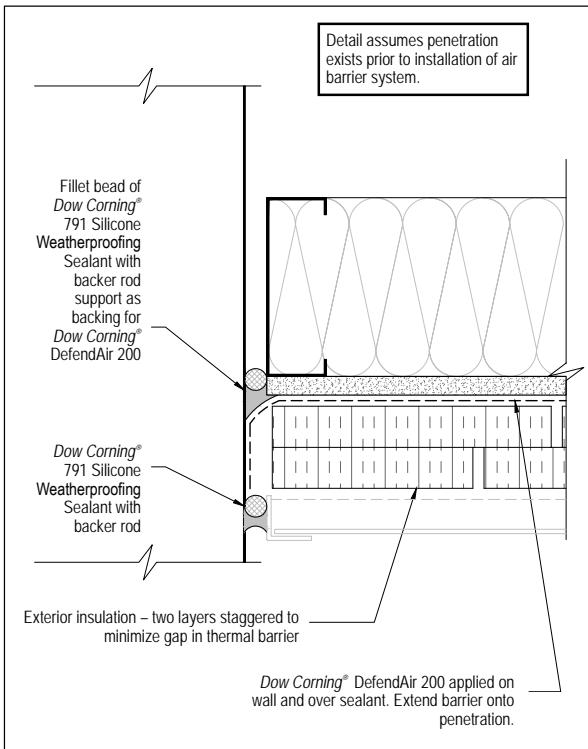

Figure 6. Vertical Wall Offset

**Window and Door Openings**

Window openings must be flashed with an approved through-wall flashing material such as Dow Corning® 778 Silicone Liquid Flashing. Dow Corning® 778 Silicone Liquid Flashing should be trowel-applied in a 20-mil (0.63 mm) wet-film thickness for this application. Best practice is to trowel apply the liquid flashing around the entire opening. At minimum, Dow Corning® 778 Silicone Liquid Flashing should be applied on the entire sill and a minimum of 6 inches (203.2 to 304.8 mm) up both vertical jambs. The flashing should be applied around the front corner of the sill and jambs, covering a minimum of 3 inches (76.2 to 101.6 mm) perimeter on the face of the sheathing. The depth of the flashing into the window opening should be a minimum of 3 inches or 1 inch (76.2 to 25.4 mm) behind where the primary air and water seal is to be installed, whichever is greater.

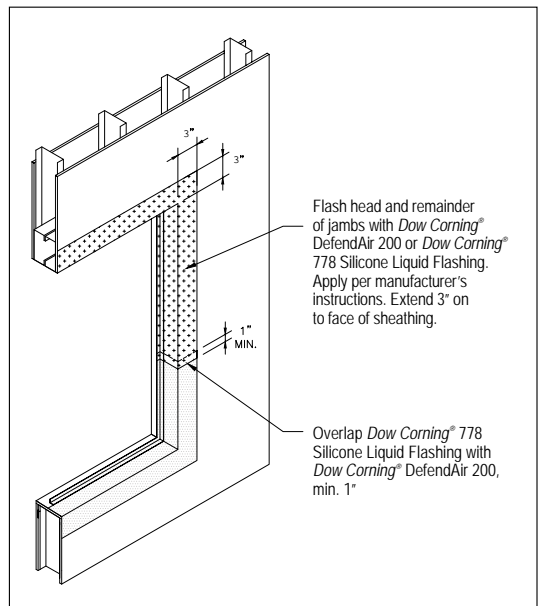

Figure 7. Window Opening – Isometric Sequencing Dow Corning® 778 Silicone Liquid Flashing

If liquid flashing is only used at the sill and lower jambs of the opening, a 15-mil (0.38mm) dry film thick layer of Dow Corning® DefendAir 200 should then be used to flash the remainder of the jambs and the head of all openings. Dow Corning® DefendAir 200 should always overlap the Dow Corning® 778 Silicone Liquid Flashing by at least 1 inch (25.4 mm). When the distance between materials in the window opening (i.e., the distance between the sheathing and the window framing) is greater than 1/8 inch (3.175 mm), a bead of sealant must be used to bridge the gap.



Example of flashing at window opening

*Dow Corning*<sup>®</sup> 791 Silicone Weatherproofing Sealant can also be used in lieu of *Dow Corning*<sup>®</sup> 778 Silicone Liquid Flashing in this application at a 25-mil (0.63 mm) wet-film thickness.

The sealing of window openings to the curtain wall or window system can be completed with a liquid-applied sealant (Figure 8) or *Dow Corning*<sup>®</sup> Silicone Transition System (Figure 9). This step can be completed before or after *Dow Corning*<sup>®</sup> DefendAir 200 is installed. When *Dow Corning*<sup>®</sup> Silicone Transition System is installed after the air and weather barrier, *Dow Corning*<sup>®</sup> DefendAir 200 should be allowed to dry for a minimum of 48 hours before the *Dow Corning*<sup>®</sup> Silicone Transition System is installed. A primer is not required when one of the recommended sealants in Table 2 Column A is used to adhere *Dow Corning*<sup>®</sup> Silicone Transition System to *Dow Corning*<sup>®</sup> DefendAir 200.

It is important to seal the absolute edge of the *Dow Corning*<sup>®</sup> Silicone Transition System. This most often requires a second line of sealant to be applied along the edge of the strip after it has been initially installed. This additional step will help ensure that no area of the substrate is left exposed once the air and weather barrier is installed and will prevent unwanted water penetration into the system.

For more information on detailing window openings, reference the Tech Talk section of this guide.

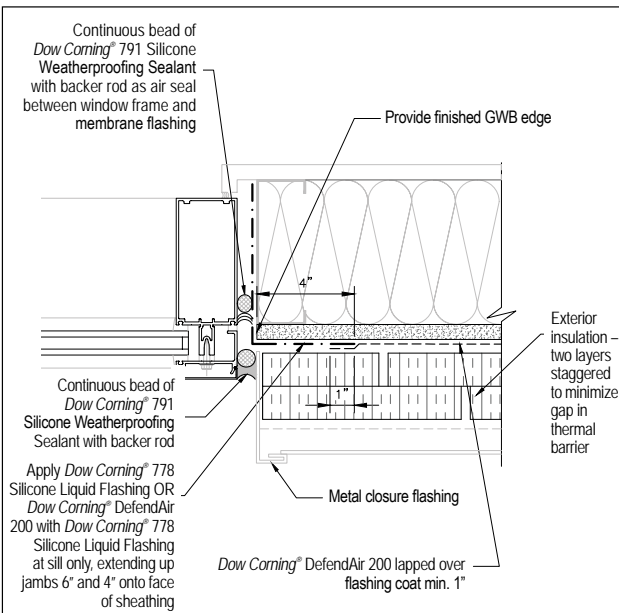

Figure 8. Curtain Wall Jamb at Flush Condition – *Dow Corning*<sup>®</sup> DefendAir 200 Flashing

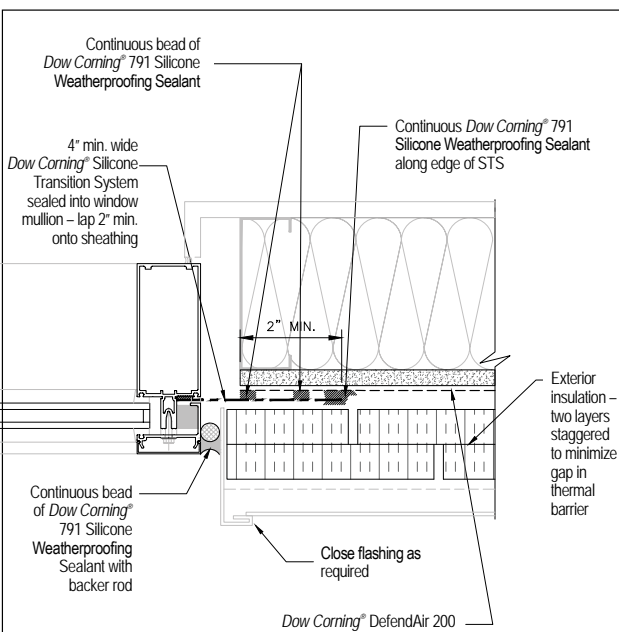

Figure 9. Curtain Wall Jamb at Flush Condition – STS Flashing



### Foundation and Roof Transitions

Foundation and roof transitions are best sealed using *Dow Corning*<sup>®</sup> Silicone Transition System. When installing *Dow Corning*<sup>®</sup> Silicone Transition System, it is important to choose a sealant that adheres well to the substrate(s). In the case of most roofing and foundation membranes, the recommended sealant is *Dow Corning*<sup>®</sup> 758 Silicone Weather Barrier Sealant. See Figures 10 and 11. A fillet bead of *Dow Corning*<sup>®</sup> 758 Sealant may be adequate to bridge the transition between the air barrier and the foundation or roof membrane. *Dow Corning*<sup>®</sup> DefendAir 200 is not approved to transition to other membranes without use of a sealant or pre-cured strip.



Example of bridging from below grade water proofing to Air Barrier using *Dow Corning*<sup>®</sup> 758 Silicone Weather Barrier Sealant

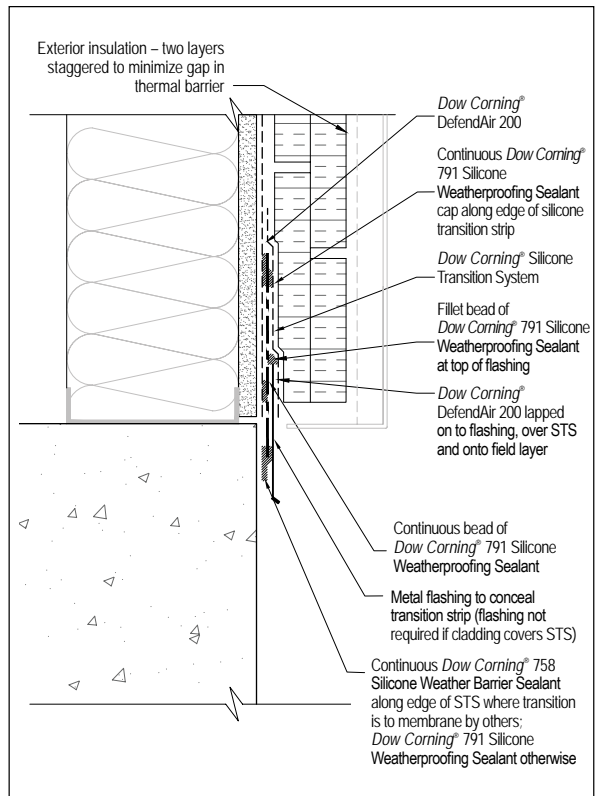

Figure 10. Stud Wall to Concrete Wall

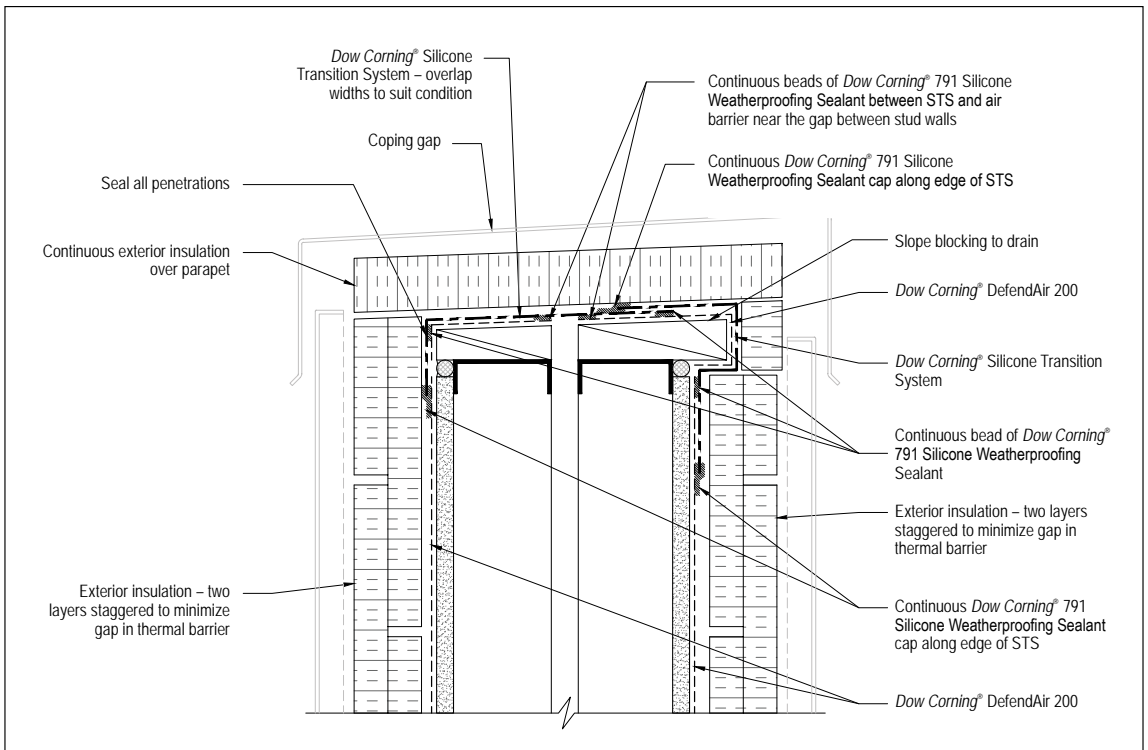

Figure 11. *Dow Corning*<sup>®</sup> Silicone Transition System at Parapet

### Step 3. Dow Corning® DefendAir Primer

*Dow Corning®* DefendAir 200 does not require a primer on most substrates. Refer to Table 2 for primer recommendations for common substrates. To determine if primer is required on other materials or on substrates that may have been contaminated by other substances, it is recommended to perform a project-specific adhesion test. The procedure for this test can be found in the “Adhesion Test Procedure” section of this guide (page 17).

When required, *Dow Corning®* DefendAir Primer is applied in one coat using either a ½- to ¾-inch (13 to 19 mm) nap roller or an airless sprayer. The primer should only be installed when temperatures are above 20°F (-6°C) and when there is no chance of rain within four hours. The expected coverage rate of *Dow Corning®* DefendAir Primer is approximately 300 square feet per gallon (7.4 square meters per liter).

Allow the primer to “dry to the touch” (30 minutes to two hours) before applying *Dow Corning®* DefendAir 200. After priming, before installing the air and weather barrier, the spray equipment should be fully cleaned or a new roller used.

### Step 4. Installing Dow Corning® DefendAir 200

*Dow Corning®* DefendAir 200 must be applied to a minimum total 15-mil (0.38 mm) dry-film thickness on the surface of the substrate (approximately 30-mil (0.76 mm) wet-film thickness) to attain air and water tightness and to qualify for a project-specific warranty. (See the “Coverage Rates” section on page 9 of this guide for more information.) *Dow Corning®* DefendAir 200 can be applied using a brush, roller (hand or power) or airless sprayer.

Prior to installing *Dow Corning®* DefendAir 200, it is important that all sealants and primers that have been installed during the wall preparation process are allowed to “dry to touch” (15-30 minutes for sealant and 30 minutes to two hours for *Dow Corning®* DefendAir Primer). Apply one coat of material around all penetrations and openings prior to the installation of the air barrier on the entire surface. This will help ensure complete coverage of these details. *Dow Corning®* DefendAir 200 should overlap the liquid flashing and all window opening detailing by a minimum of 1 inch (25.4 mm).

Do not thin or cut back *Dow Corning®* DefendAir 200.

#### Hand Roller Application

Apply *Dow Corning®* DefendAir 200 using a ¾- to 1½-inch (9.5 to 38 mm) nap, polyester or 50/50 polyester/wool blend roller cover. In general, smaller nap lengths are more suitable for smooth substrates. Apply the coating in a fan (W-) pattern to achieve uniform thickness. The coating should be applied in two 15- to 18-mil (0.38 to 0.46 mm) wet-thickness coats. Typically, two 15- to 18-mil (0.38 to 0.46 mm) wet coats will result in the required 15-mil dry-coating thickness (DFT); however, an additional

coat may be required depending on surface texture or porosity. If it is found that an additional coat is necessary to achieve 15-mil DFT on the surface of the substrate, it may be possible to utilize *Dow Corning®* DefendAir Primer before applying *Dow Corning®* DefendAir 200 to reduce the amount of *Dow Corning®* DefendAir 200 being absorbed. This may decrease the need for extra coats of *Dow Corning®* DefendAir 200.

Allow the coating to dry to the touch (typically two to four hours) before applying the next coat.

#### Power Roller Application

Apply *Dow Corning®* DefendAir 200 using a ½- to 1½-inch (12.7 to 38 mm) nap, polyester or 50/50 polyester/wool blend roller cover. The coating should be applied in two 15- to 18-mil (0.38 to 0.46 mm) wet-thickness coats. Typically, two 15- to 18-mil (0.38 to 0.46 mm) wet coats will result in the required 15-mil dry-coating thickness; however, thicker coats may be required depending on surface texture or porosity. Up to a 25-mil (0.63 mm) wet-thickness coat can be applied in one pass using a power roller.

A low air pressure is needed to pump the material to the roller head. Pull the application trigger often to apply more material to the roller. There is too much material being applied in one coat when the roller slides instead of rolling.

Allow the coating to dry to the touch (typically two to four hours) before applying a second coat.

#### Spray Application

*Dow Corning®* DefendAir 200 can be installed on most substrates, in one 30-mil (0.76 mm) wet coat using an airless sprayer. Two 18- to 20-mil (0.46 to 0.51 mm) wet coats may be required to achieve the required thickness on some extremely porous substrates. There is no maximum installation thickness for *Dow Corning®* DefendAir 200, but the air barrier will start to sag when approximately 60-mil (1.52 mm) wet-film thickness is achieved in one coat. (For information on how the applied thickness of *Dow Corning®* DefendAir 200 affects the vapor permeability of the air barrier, please see the Tech Talk section of this manual.)

Refer to the equipment manual for your spray equipment for detailed information on tip size selection, tip wear and optimal pressure. A minimum 0.021-inch (0.53 mm) tip is recommended to spray *Dow Corning®* DefendAir 200. The optimal tip sizes range from 0.025 inch to 0.031 inch (0.63 mm to 0.79 mm). The larger the tip size, the more pressure will be required to spray the material – and the faster the application of the air and weather barrier. Ensure that your spray equipment is able to accommodate the tip size you wish to use before starting the application.

When spraying *Dow Corning®* DefendAir 200, start with a low pressure and increase the pressure until a uniform pattern is sprayed. Increase the size of the tip if more material is desired. As the tip wears, the pressure on the sprayer will need to be increased to maintain an even application of material. If the air and weather barrier

begins to exhibit pinholing or fisheyes, reduce the pressure of the sprayer and/or move the sprayer head farther away from the substrate.

A respirator is not required when spraying *Dow Corning®* DefendAir 200. Personal preference may be to wear a mask.

## Drying Time

After the final coat of the air barrier has been applied, the average drying time of *Dow Corning®* DefendAir 200 is four to 12 hours, depending on coat thickness, temperature, humidity and wind conditions.

*Dow Corning®* DefendAir 200 will attain full adhesion and physical properties in seven to 14 days.

## Cold Temperature Considerations

*Dow Corning®* DefendAir 200 can be applied at temperatures as low as 20°F (-6°C). If temperatures drop below 20°F (-6°C) after *Dow Corning®* DefendAir 200 is applied, the coating will freeze on the surface until the temperature increases. This will not affect the cured properties of the air barrier but will extend the drying time. *Dow Corning®* DefendAir 200 requires temperatures higher than 20°F (-6°C) for a cumulative total of 24 hours to dry. *Dow Corning®* DefendAir 200 will attain full adhesion and physical properties in seven to 14 days.

Roller application of the air barrier at low temperature will require two coats. The air barrier should “dry to touch,” not simply freeze, between coats. Application equipment such as rollers and the tips of spraying equipment should be kept above 32°F (0°C) when not in use. When the temperatures are consistently below 40°F (4°C), allow the air barrier to dry a minimum of three days prior to applying other materials to the surface of the air barrier.

## Fasteners Installed After Air Barrier

*Dow Corning®* DefendAir 200 successfully passes ASTM D1970 for Nail Sealability when applied at 15 mils.

In addition, *Dow Corning®* DefendAir 200 has been tested in full wall assemblies with a number of different fasteners installed through the air barrier for air infiltration (ASTM E283) and water infiltration (ASTM E331) both before and after structural loading (ASTM E330). This testing included fasteners that were installed through panel furring strips and through foam insulation. None of the fasteners tested affected the air leakage rate of the wall assembly. The following recommendations are for maintaining a watertight building envelope.

All fasteners with a diameter less than ¼ inch (6.4 mm) passed this testing without any extra preparation or post-sealing. For fasteners greater than ¼ inch (6.4 mm) in diameter, some pre- or post-sealing of the fastener was required. The best practice for larger fasteners is to tool a thin layer (25 mils [0.64 mm]) of sealant onto the air

barrier prior to installation of fastener (see Table 2, Column B for options). The fastener can be installed at any time after the sealant. The amount of cure of the sealant does not affect the performance. This method worked for all fasteners tested, but other options may be available for specific hardware. For detailed preparation recommendations for the specific fasteners tested, refer to the Tech Talk section of this manual.

If fasteners miss the stud during installation, best practice is to remove the fastener from the wall and seal the hole with a sealant from Table 2, Column B.

## Quality Control

Wet-film thickness can be measured using a wet mil gauge. When measuring the thickness of *Dow Corning®* DefendAir 200 that has been installed on porous substrates, wait five minutes before measuring the coating thickness. This measures the amount of material that remains on the surface of the substrate, after any material has been absorbed. Document the location and thickness from the testing in a quality control form (an example can be found in the Tech Talk section). Wet-film thicknesses should be measured on every floor and elevation to ensure proper air barrier thickness is being applied. As a guideline, measure at least every 10 feet during application.

At the beginning of the project, it is recommended to measure the dry film thickness of the air barrier in the same area as where the wet-film thickness was measured. This will determine the actual absorption rate of the air barrier into the project substrate. A full 15-mil (0.38 mm) dry thickness must remain on the surface of the substrate.



Demonstrating usage of wet mil gauge

At least one day after the air barrier is applied, visual inspection should be performed on the entire wall area that has been coated to assess that the wall has an adequate coating thickness. Any areas where the text on the underlying sheathing is visible, there is insufficient air barrier material and an additional coat of *Dow Corning®* DefendAir 200 should be applied.





Post application inspection shows sheathing joint not properly sealed. Reseal with sealant.

The visual assessment should also look at seams between sheathing panels, mortar joints and screw heads to ensure that they have all been covered. After *Dow Corning*<sup>®</sup> DefendAir 200 has been installed and allowed to dry, the white or gray color of the coating allows joints and deficiencies in the substrate that were not sealed before or during the application of the air and weather barrier to become visible. Screw heads and joints that did not receive enough material can be sealed over the air barrier using *Dow Corning*<sup>®</sup> 791 Silicone Weatherproofing Sealant or another sealant found in Column B of Table 2 or by touching up the area with *Dow Corning*<sup>®</sup> DefendAir 200.

## Equipment Cleanup

*Dow Corning*<sup>®</sup> DefendAir 200 is a water-based material. Any equipment that is used to install the air and weather barrier can be cleaned using water; no solvents are required. Spray equipment can be cleaned by running water through the sprayer. It is recommended to clean the equipment at least every five working days. If a longer period between cleanings is needed, sprayability of the material should be verified by the contractor.

## Disposal

See the Material Safety Data Sheet (MSDS) for disposal information.

## Adhesion Test Procedure

For uncommon materials or substrates that may have been contaminated by other materials, it is recommended an adhesion test be performed to determine whether a primer is required.

The most reliable method for testing adhesion of an air barrier to a substrate is to follow ASTM D4541. This test requires the use of specialized equipment and a metal loading fixture (dolly) to be adhered to the air barrier (Figure 12). LocTite Hysol 907 adhesive can be used to adhere the dolly to *Dow Corning*<sup>®</sup> DefendAir 200. Current air barrier standards state that the air barrier should have an adhesive strength of greater than 16 psi (110kPa).



Figure 12. Adhesion Test Using ASTM D4541

Another option available for adhesion testing is to perform a “cheesecloth” test (Figure 13). This test is ideal for concrete and masonry substrates. Some substrates, especially gypsum sheathing, may produce a false-negative result when using this test method.

1. Prepare surfaces as described in the section on Substrate Preparation and Evaluation (page 10).
2. Use of a primer is optional, but testing is required to ensure sufficient adhesion in primerless applications. If primer is used, apply per the application method and allow it to dry.
3. Apply the first coat of *Dow Corning*<sup>®</sup> DefendAir 200 at a rate of 15-mil (0.38 mm) wet-film thickness. Embed a cheesecloth strip (1 x 12 inch [25 x 305 mm]) in the wet coating with a paintbrush.
4. Apply the second coat over the cheesecloth at the same 15-mil (0.38 mm) wet-film thickness and allow to fully dry for seven to 14 days. This is an adhesion test only; additional coats may be required to achieve thickness requirements.
5. Test adhesion of the coating by pulling the uncoated part of the cheesecloth at a 180° angle at a slow, steady rate.
6. Inspect and note the percent cohesive failure (percentage of coating material left on the wall surface). At least 80 percent of the coating should remain on the substrate.
7. If 80 percent retention is not achieved, the test should be repeated using *Dow Corning*<sup>®</sup> DefendAir Primer. If necessary, contact Dow Corning Technical Service for further instruction.

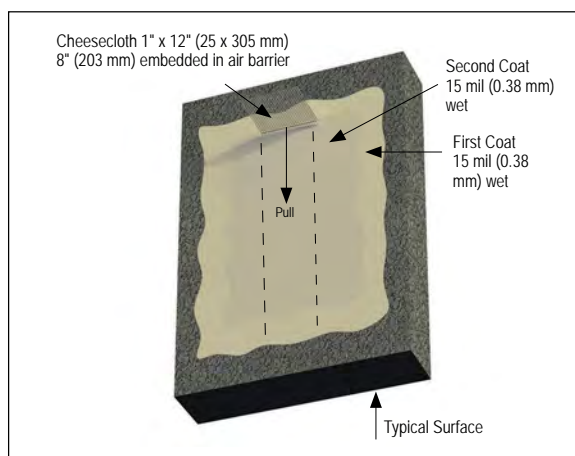

Figure 13. Adhesion Test Procedure Diagram

## Product Limitations

*Dow Corning®* DefendAir 200 is not designed for use on horizontal surfaces or in below-grade applications.

*Dow Corning®* DefendAir 200 should not be installed on newly applied or green cementitious materials; industry guidelines recommend at least 28 days of cure before painting or coating the substrates (see SSPC 2010 Painting Manual, Chapter 3.1 – Concrete Surface Preparation).

*Dow Corning®* DefendAir 200 does not adhere to high-density polyethylene-backed materials. When using these materials in conjunction with *Dow Corning®* DefendAir 200, please contact Dow Corning for assistance.

## Appendix I – Material Compatibility

*Dow Corning®* DefendAir 200 has been tested with a selection of materials offered by other manufacturers in the industry. For information on compatibility with the materials provided by other manufacturers, please contact your local Dow Corning representative. Project-specific testing typically is recommended. Please reference the Tech Talk section for more information on material compatibility on page 52.

## Appendix II – Referenced ASTM Standards

ASTM E2178 Standard Test Method for Air Permeance of Building Materials

ASTM E2357 Standard Test Method for Determining Air Leakage of Air Barrier Assemblies

ASTM D1970 Standard Specification for Self-Adhering Polymer Modified Bituminous Sheet Materials Used as Steep Roofing Underlayment for Ice Dam Protection (Used for Nail Sealability)

ASTM D543 Standard Practices for Evaluating the Resistance of Plastics to Chemical Reagents

ASTM D4541 Standard Test Method for Pull-Off Strength of Coatings Using Portable Adhesion Testers

ASTM E283 Standard Test Method for Determining Rate of Air Leakage Through Exterior Windows, Curtain Walls, and Doors Under Specified Pressure Differences Across the Specimen

ASTM E330 Standard Test Method for Structural Performance of Exterior Windows, Doors, Skylights and Curtain Walls by Uniform Static Air Pressure Difference

ASTM E331 Standard Test Method for Water Penetration of Exterior Windows, Skylights, Doors, and Curtain Walls by Uniform Static Air Pressure Difference

## Health and Environmental Information

To support customers in their product safety needs, Dow Corning has an extensive Product Stewardship organization and a team of Product Safety and Regulatory Compliance (PS&RC) specialists available in each area.

For further information, please see our website, **dowcorning.com**, or consult your local Dow Corning representative.

## Contact us

Learn more about the *Dow Corning*<sup>®</sup> Silicone Air Barrier System and our full range of High Performance Building Solutions, including service and support, at **BuildaBetterBarrier.com**.

Dow Corning has sales offices, manufacturing sites, and science and technology laboratories around the globe. Find local contact information at **dowcorning.com/ContactUs**.

**BuildaBetterBarrier.com**

Images: AV22605, AV22641, AV22606, AV22645, AV22647, AV22611, AV22639, AV22646, AV22648, AV22500, AV22640, AV20411, AV20715, AV22644, AV20400, AV20401, AV20402, AV20405, AV20403, AV20404, AV20409, AV20406, AV20407, AV20410, AV20408, AV22643, AV20408, AV22648, AV22649

### HANDLING PRECAUTIONS

PRODUCT SAFETY INFORMATION REQUIRED FOR SAFE USE IS NOT INCLUDED IN THIS DOCUMENT. BEFORE HANDLING, READ PRODUCT AND MATERIAL SAFETY DATA SHEETS AND CONTAINER LABELS FOR SAFE USE, PHYSICAL AND HEALTH HAZARD INFORMATION.

THE MATERIAL SAFETY DATA SHEET IS AVAILABLE ON THE DOW CORNING WEBSITE AT DOWCORNING.COM, OR FROM YOUR DOW CORNING SALES APPLICATION ENGINEER, OR DISTRIBUTOR, OR BY CALLING DOW CORNING CUSTOMER SERVICE.

### LIMITED WARRANTY INFORMATION – PLEASE READ CAREFULLY

The information contained herein is offered in good faith and is believed to be accurate. However, because conditions and methods of use of our products are beyond our control, this information should not be used in substitution for customer's tests to ensure that our products are safe, effective and fully satisfactory for the intended end use. Suggestions of use shall not be taken as inducements to infringe any patent.

Dow Corning's sole warranty is that our products will meet the sales specifications in effect at the time of shipment.

Your exclusive remedy for breach of such warranty is limited to refund of purchase price or replacement of any product shown to be other than as warranted.

**TO THE FULLEST EXTENT PERMITTED BY APPLICABLE LAW, DOW CORNING SPECIFICALLY DISCLAIMS ANY OTHER EXPRESS OR IMPLIED WARRANTY OF FITNESS FOR A PARTICULAR PURPOSE OR MERCHANTABILITY.**

**DOW CORNING DISCLAIMS LIABILITY FOR ANY INCIDENTAL OR CONSEQUENTIAL DAMAGES.**

*Dow Corning* is a registered trademark of Dow Corning Corporation.

*We help you invent the future* is a trademark of Dow Corning Corporation.

*Build a Better Barrier* is a trademark of Dow Corning Corporation.

DensGlass<sup>®</sup> is a registered trademark of Georgia-Pacific Gypsum LLC.

THERMAX<sup>™</sup> is a trademark of The Dow Chemical Company.

SECUROCK<sup>®</sup> is a registered trademark of USG.

©2015 Dow Corning Corporation. All rights reserved.