



DOWSIL™ 982 Silicone Insulating Glass Sealant

Two-part silicone sealant for use as a secondary sealant in insulating glass units

Features & Benefits

- Cures to form a durable, long-lasting, high-modulus, flexible, weather tight bond
- Meets ASTM C-1369 Specification for structurally glazed insulating glass units
- Excellent unprimed adhesion to glass and metal substrates, such as galvanized steel and aluminum
- Consistently nonslump, permitting automated glazing
- 12 month shelf life from date of manufacture
- Noncorrosive byproducts
- Low shrinkage (< 5 percent)

Composition

- Two-part silicone sealant

Applications

- DOWSIL™ 982 Silicone Insulating Glass sealant is intended for use as a secondary sealant in a dual-sealed insulating glass unit (see Figure 1). A primary seal, typical being a polyisobutylene mastic, is required to prevent moisture vapor from transmitting into the airspace of the insulating glass unit. When used in IG unit fabrication, DOWSIL™ 982 Silicone Insulating Glass Sealant bonds to typical IG substrates and completes a weather-resistant unit capable of meeting the ASTM E-2190 specification which is a requirement of NFRC 706 certification.
- DOWSIL™ 982 Silicone Insulating Glass Sealant can also be used as a secondary edge seal in an insulating glass unit that will be structurally glazed. In the event that the sealant is used in this application it is the IG manufacturers' responsibility to ensure suitability and conduct structural bite calculations using industry accepted load sharing methods.

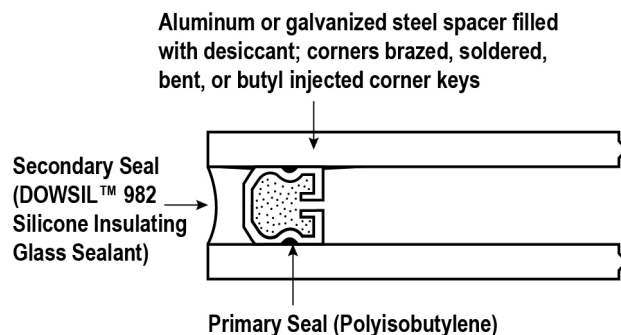

Figure 1: Dual-seal Type

Typical Properties

Specification Writers: These values are not intended for use in preparing specifications.

Test ¹	Property	Unit	Result
As Supplied - Base			
	Color/Physical Form		White/paste
CTM 0097	Specific Gravity		1.38
ASTM C 1183	Extrusion Rate, 90 psi, 1/8" Orifice	g/min	160
As Supplied – Black Curing Agent			
	Color/Physical Form		Black/pourable liquid
CTM 0097	Specific Gravity		1.02
As Supplied – Gray Curing Agent			
	Color/Physical Form		Gray/pourable liquid
CTM 0097	Specific Gravity		1.22
As Catalyzed – Mixed at 9:1 Base-to-Curing Agent by Volume			
CTM 0092	Working Time (Snap Time) ²	minutes	30–90
ASTM D 2202	Flow/Sag (Slump)	inches (mm)	< 0.2 (< 5.1)
SCAQMD ³	VOC Content – Black	g/L	14
	VOC Content – Gray	g/L	13
As Cured – 7 Days at 25°C (77°F) and 50 Percent Relative Humidity			
ASTM C 661	Durometer Hardness, Shore A	points	43
ASTM D 412	Tensile Strength	psi (MPa)	228 (1.6)
ASTM D 412	Elongation	percent	219
ASTM C 794	Adhesion-in-Peel, Cohesive Failure Aluminum/Glass	%%/%%	100/100

1. CTMs (Corporate Test Methods) correspond to standard ASTM (American Society of Testing and Materials) tests in most instances. Copies of CTMs are available upon request.
2. Snap times will vary depending on temperature, humidity and technique used. Dow recommends snap time be repeated daily using the same method and it be used as an indicator value, with a focus on significant deviations from the current trend as a potential signal that the mix ratio could be off.
3. Calculation based on South Coast Air Quality Management District of California.

Description

DOWSIL™ 982 Silicone Insulating Glass Sealant is a two-part silicone sealant. As supplied, the base component, DOWSIL™ 982 Silicone Insulating Glass Sealant-Base, is a smooth, white paste. The curing agent component, DOWSIL™ 982 2-Part Curing Agent, is a pourable liquid available in black or gray. Once mixed at the proper base-to-curing agent ratio, the material cures to a durable, high-modulus, flexible silicone seal that is chemically stable.

DOWSIL™ 982 Silicone Insulating Glass Sealant retains design properties and maintains adhesion to substrates, keeping insulated glass seals weatherproof, after years of exposure.

How to Use

Design Considerations

Insulating glass units intended for conventional dry glazing or residential window application should be designed with the secondary sealant dimensions in accordance with the "Sealant Manufacturers Minimum Sealant Dimensions and Placement Survey," distributed by SIGMA, 01 July 1989.

Insulating glass units intended for structural silicone glazing applications should contain secondary seal depths as determined by industry-accepted standards, such as the trapezoidal load distribution rule and load-sharing principles.

Adhesion and compatibility should be evaluated before sealant use. If requested, Dow may provide assistance in performing adhesion testing to coated glass¹ or spacer surfaces before using DOWSIL™ 982 Silicone Insulating Glass Sealant in production quantities.

Surface Preparation

Before using this product, clean all surfaces, removing all foreign matter and contaminants, such as grease, oil, dust, water, frost, surface dirt, old sealants or glazing compounds and protective coatings.

Clean all metal, glass and plastic surfaces by mechanical solvent procedures. Always wipe solvents on and off with clean, oil- and lint-free cloths.²

¹Some coatings may require edge deletion for optimal long term system performance. Contact your glass supplier for recommendations.

²Follow solvent manufacturer's recommended safe handling instructions and applicable federal, state and local laws.

Mixing

To obtain ultimate physical properties, DOWSIL™ 982 Silicone Insulating Glass Sealant-Base and DOWSIL™ 982 2-Part Curing Agent should be thoroughly mixed using automated two part mixing and dispensing equipment. DOWSIL™ 982 Silicone Insulating Glass Sealant is compatible with commercially available equipment. Mixing by hand or utilizing small mechanical mixing devices will not produce satisfactory results.

DOWSIL™ 982 Silicone Insulating Glass Sealant is supplied as two separate components. As a custom feature for the customer, the cure rate may be adjusted by changing the base-to-curing agent mix ratio from 9:1 to 10:5:1 by volume. Sealant physical properties are not significantly changed over this range. Changes in the temperature and humidity of the environment, however, will affect snap time. See Table 1 for ratio weight volumetric equivalents.

Because of its reactivity with atmospheric moisture, DOWSIL™ 982 2-Part Curing Agent should not be exposed to air for prolonged periods.

During shutdown of mixing equipment, dispensing and mixing lines should be purged with uncatalyzed base to minimize sealant buildup.

Lot matching of DOWSIL™ 982 Silicone Insulating Glass Sealant-Base and DOWSIL™ 982 2-Part Curing Agent is NOT required.

How to Use (Cont.) Testing

It is recommended for several in-house quality control tests to ensure optimum sealant performance. These tests include:

- Butterfly test to ensure proper mix
- Snap time or cure test to ensure expected sealant cure rate at proper mix ratio
- Tab adhesion test to ensure proper sealant adhesion to production surfaces

These tests should be performed every time lots of base or curing agents are changed, or every time the production line is started. Specific procedures for these recommended tests can be supplied.

Tooling

To obtain optimum adhesion, joints should be tooled immediately after sealant application to ensure complete substrate contact.

Table 1: Weight Equivalents of Volumetric Mixing Ratios

Volume Ratio	Equivalent Weight Ratio	
	Black Curing Ratio	Gray Curing Ratio
9:1 to 10.5:1	12:1 to 14:1	10:1 to 12:1

Handling Precautions

PRODUCT SAFETY INFORMATION REQUIRED FOR SAFE USE IS NOT INCLUDED IN THIS DOCUMENT. BEFORE HANDLING, READ PRODUCT AND SAFETY DATA SHEETS AND CONTAINER LABELS FOR SAFE USE, PHYSICAL AND HEALTH HAZARD INFORMATION. THE SAFETY DATA SHEET IS AVAILABLE ON THE DOW WEBSITE AT DOW.COM, OR FROM YOUR DOW SALES APPLICATION ENGINEER, OR DISTRIBUTOR, OR BY CALLING DOW CUSTOMER SERVICE.

Usable Life and Storage

When stored in closed, airtight containers at or below 32°C (90°F), DOWSIL™ 982 Silicone Insulating Glass Sealant-Base and DOWSIL™ 982 2-Part Curing Agent will have a shelf life of 12 months from date of manufacture. Refer to product packaging for “Use By” date.

Packaging Information

DOWSIL™ 982 Silicone Insulating Glass Sealant-Base and DOWSIL™ 982 2-Part Curing Agent are sold as separate components, allowing manufacturers to purchase and create their own kits.

The base component is available in drums. The curing agent is supplied separately in both pails and drums.

Limitations

DOWSIL™ 982 Silicone Insulating Glass Sealant should not be applied:

- As a primary or single seal in an insulating glass unit
- To building materials that bleed oils, plasticizers or solvents – materials such as impregnated wood, oil-based caulks, green or partially vulcanized rubber gaskets and tapes

Limitations (Cont.)

- On food contact surfaces – this product does not comply with FDA food additive regulations
- In below-grade applications
- In contact with or exposed to sealants that liberate acetic acid
- In continuous immersion in water

This product is neither tested nor represented as suitable for medical or pharmaceutical uses.

Health and Environmental Information

To support customers in their product safety needs, Dow has an extensive Product Stewardship organization and a team of product safety and regulatory compliance specialists available in each area.

For further information, please see our website, dow.com or consult your local Dow representative.

Disposal Considerations

Dispose in accordance with all local, state (provincial) and federal regulations. Empty containers may contain hazardous residues. This material and its container must be disposed in a safe and legal manner.

It is the user's responsibility to verify that treatment and disposal procedures comply with local, state (provincial) and federal regulations. Contact your Dow Technical Representative for more information.

Product Stewardship

Dow has a fundamental concern for all who make, distribute, and use its products, and for the environment in which we live. This concern is the basis for our product stewardship philosophy by which we assess the safety, health, and environmental information on our products and then take appropriate steps to protect employee and public health and our environment. The success of our product stewardship program rests with each and every individual involved with Dow products - from the initial concept and research, to manufacture, use, sale, disposal, and recycle of each product.

Customer Notice

Dow strongly encourages its customers to review both their manufacturing processes and their applications of Dow products from the standpoint of human health and environmental quality to ensure that Dow products are not used in ways for which they are not intended or tested. Dow personnel are available to answer your questions and to provide reasonable technical support. Dow product literature, including safety data sheets, should be consulted prior to use of Dow products. Current safety data sheets are available from Dow.

dow.com

NOTICE: No freedom from infringement of any patent owned by Dow or others is to be inferred. Because use conditions and applicable laws may differ from one location to another and may change with time, Customer is responsible for determining whether products and the information in this document are appropriate for Customer's use and for ensuring that Customer's workplace and disposal practices are in compliance with applicable laws and other government enactments. The product shown in this literature may not be available for sale and/or available in all geographies where Dow is represented. The claims made may not have been approved for use in all countries. Dow assumes no obligation or liability for the information in this document. References to "Dow" or the "Company" mean the Dow legal entity selling the products to Customer unless otherwise expressly noted. NO WARRANTIES ARE GIVEN; ALL IMPLIED WARRANTIES OF MERCHANTABILITY OR FITNESS FOR A PARTICULAR PURPOSE ARE EXPRESSLY EXCLUDED.

